

Battery concepts for smart utility meters – The requirements and proving their suitability

by Dr. Thomas Dittrich, Tadiran Batteries GmbH

Smart meters make it possible to cut energy consumption in the range of 10 % to 15 %. Studies [1, 2] show that this enables central requirements of the European Energy Efficiency Directive [3] to be met. Pilot projects are currently being implemented in several European countries.

Batteries are used as a power source for various functions in both the meters themselves and for collecting and transmitting data. The demands on service life, compactness and electrical values are enormous. The batteries used are required to last between 10 and 20 years. Proving this capability is a big challenge [4].

Based on four examples, the requirements will be discussed in detail, with a particular focus on how adherence to these requirements can be ensured.

What makes meters smart?

Meters for electricity, gas, water or heating are classed as smart if they are designed such that consumption data is available to the user in real time, and usage can be controlled economically. Smart meters are largely digital, and at least measurement data is digitalised. Separate or integrated additional modules are used for communication and control. Such modules can enable remote meter reading, tariff switching or a prepayment function. One important use is the presentation of usage data on either a separate display device or a home computer.

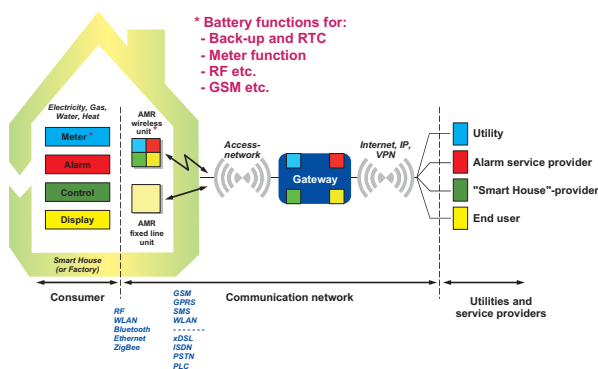

Figure 1
Network architecture with smart meters

Here, batteries are used as a power source for various functions. In electricity meters, this is typically to provide a backup power supply for the real-time clock in the event of a power cut. Smart meters for gas, water and heating on the other hand are often powered by the battery alone.

In the case of electricity meters, data transmission often occurs over the electricity network itself

(power line communication, PLC). For the other types of meters, communication tends to occur via radio. However, the electrical requirement for this varies greatly depending on the transmission path.

The degree of implementation of smart meter systems varies greatly across the European Community. For instance, in Italy, almost all electricity meters are smart (*Telegestore* project by ENEL involving 30 million electronic meters). Large projects are also underway in Sweden and in the Netherlands. In the Netherlands and Great Britain in particular, the gas meter market is being incorporated into smart metering projects. Several pilot projects are now also in progress in Germany, mainly involving electricity meters.

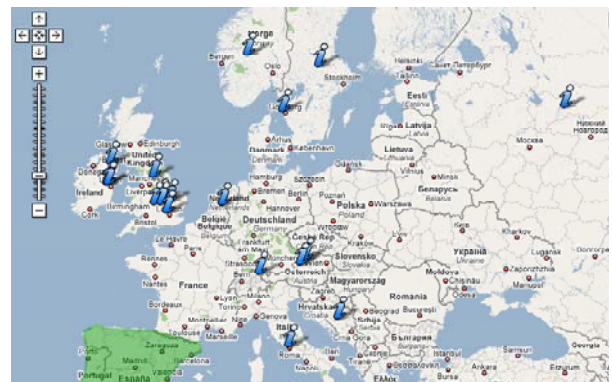

Figure 2
Map of smart metering projects in Europe [5]

Batteries for back-up and RTC

Smart electricity meters require a *real time clock* (RTC) that also carries on running in the event of a power cut. A back-up battery is needed to achieve this. A SuperCap cannot ensure this function, as the delay between manufacturing and installation normally exceeds its time buffer. In addition, a CMOS-RAM can be used instead of an EEPROM if a buffer battery is in place anyway. The demands placed on the buffer battery are listed in [Table 1](#).

Application	Smart electricity meter
Voltage (U_{\min})	2.5 volts
Storage	1 year at 30 μ A
Back-up time	10 min per year at 200 μ A
Temperature	± 0 °C ... +50 °C
Service life	20 years

[Table 1](#)
Typical battery requirements for back-up and RTC

System	Voltage per cell	Seal	Service life (years)
Lithium button cell	2.7 – 3.0 V	Polymer, crimp seal	3 – 7
BR-, CR-battery	2.7 – 3.0 V	Polymer, crimp seal	5 – 10
LTC battery	3.4 – 3.6 V	Glass-to-metal seal, welding	10 – 20

[Table 2](#)
System comparison: batteries for back-up and RTC

Various lithium battery systems come into consideration for this application ([Table 2](#)). 3-Volt systems are standardized under the names BR and CR, and can be used for minimum voltages of 2.7 Volts and lower.

These batteries usually have a polymer seal in a crimped design. In the form of button cells, they can reach a typical service life of 3 to 7 years. In the case of somewhat larger round cell batteries, the seal is generally more complex. These batteries have a typical service life of 5 to 10 years. Lithium-thionyl chloride (LTC) batteries have a somewhat higher voltage, and can be used for minimum voltages of 3.4 Volts and lower.

Their seals are more complex. The can and cover are welded together. A compression glass seal provides insulation between the positive and negative terminals. These batteries achieve a typical service life of 10 to a proven 20 years [\[4\]](#).

One way of testing a battery's leak tightness for long-term use is to determine the mass loss during storage at high temperatures. [Table 3](#) contains values for storage at 70 °C over a period of 3 months. The results vary significantly, ranging from a 0.007 g mass loss (manufacturer A) through to a 0.21 g mass loss (manufacturer C), although all three battery types have a similar mechanical structure in principle and the same dimensions. From the point of view of the expected service life, the type with the lowest loss of mass should be given initial preference. Lithium-thionyl chloride batteries are normally not available in this size. However, they demonstrate no loss in mass whatsoever during this test.

Type	Manufacturer	Mass (before)	Mass (after)	Loss in mass
BR $\frac{3}{4}$ A	A	12.8665 g	12.8594 g	0.007 g
CR $\frac{3}{4}$ A	B	15.5018 g	15.4020 g	0.100 g
CR $\frac{3}{4}$ A	C	15.7384 g	15.5280 g	0.210 g

[Table 3](#)
Loss in mass following 3 months' storage at +70 °C

Although the battery from manufacturer A showed the lowest mass loss, following a month in storage conditions where the temperature varied between -25 °C and +60 °C, this system also displayed visible electrolyte salt deposits around the seals. This observation is also not usually observed in batteries with a glass/metal insert, such as lithium-thionyl chloride.

However, it is appropriate nevertheless to subject the stability of the glass in this seal system to further tests. Lithium-thionyl chloride batteries from manufacturers D and E were stored upside-down at 100 °C for 6 weeks. The batteries were then opened (under observance of safety regulations), and the covers and current collectors were separated, cleaned and inspected under a microscope. In the case of manufacturer D, the glass on the inner side that came into contact with electrolytes was just as clean and undamaged as on the outside. In contrast, in the case of manufacturer E, the glass on the entire insulation path was corroded, which was evidenced by a

blackening of the glass. Further investigations resulted in the conclusion that this corrosion can lead to complete self-discharging of the battery within a few months or years.

Another method for proving the service life of a battery system is, of course, long-term discharge. One way of speeding up such a test is to increase the temperature. Figure 3 shows the results of discharging a ½AA size lithium-thionyl chloride battery at a load of 560 kΩ (around 6 μA) and a temperature of 150 °C. This battery is a special version that is designed to resist internal pressure at this temperature. These results can be used as a proof for the service life of back-up batteries from this manufacturer.

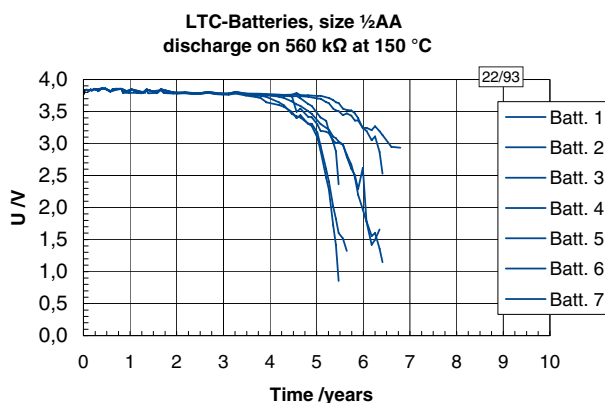

Figure 3 Long-term discharge of size ½AA LTC batteries at 560 kΩ and 150 °C

Batteries for meter functions

New smart meters for gas, water and heating that are being developed work electronically and require an independent power source. These meters normally work with ultrasound according to the Doppler principle. The temperature is also recorded electronically. In the case of mechanical meters, suitable additional devices allow measurement data to be converted into digital format. Add-on devices such as these also require power sources. They function, for instance, in that the display is converted into electronic signals with the help of an imaging function. Temperatures are normally not recorded in this case. Typical requirements placed on the battery are summarised in Table 4.

Application	Electronic gas meter
Voltage (U_{\min})	3.2 Volts
Operation	80 μA continuous current 10 mA for 11 ms every 2 s
Average current	160 μA
Temperature	-20 °C ... +60 °C
Service life	11.5 years
Capacity requirement	16.2 Ah

Table 4 Typical battery requirements for meter function

System	Voltage per cell	No. of cells	Nominal capacity	Service life (years)
Alkaline	1.1 – 1.5 V	s3p1 D	12 Ah	3 – 7
BR-, CR-battery	2.7 – 3.0 V	s2p2 C	10 Ah	5 – 10
LTC battery	3.2 – 3.6 V	s1p1 D	19 Ah	10 – 20

Table 5 System comparison: batteries for meter functions

In principle, various battery systems can be used for an electronic meter. Several systems and their main properties are listed in Table 5. As a result of the voltage level, with certain systems, several cells must be connected in series. The required capacity may also make it necessary to connect several cells in parallel. In the example of an electronic gas meter, only the LTC system can fulfil the requirements with just one cell. This system also has the longest service life.

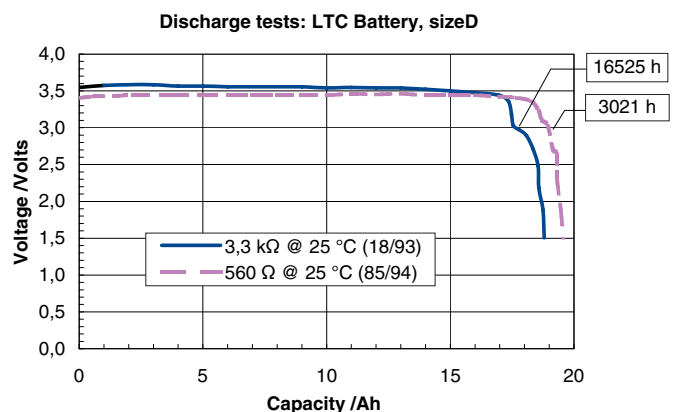

Figure 4 Discharge curves of D size LTC batteries

By means of various discharge tests, it is possible to determine the capacity, service life and voltage of the battery under usage conditions.

Figure 4 shows the discharge curves of size D LTC batteries with various discharge resistors. Discharging the batteries in this way makes it possible to demonstrate the batteries' capacity under various loads.

Figure 5 shows the result of a long-term test on this battery, carried out over 13 years. In this test, the current profile of an electronic meter was simulated by a resistance load with superimposed current pulses.

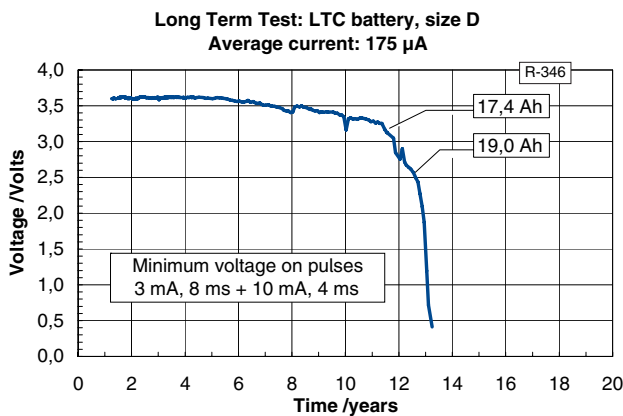

Figure 5
Meter simulation with basic and pulse load. D size LTC battery at an average current of 175 µA.

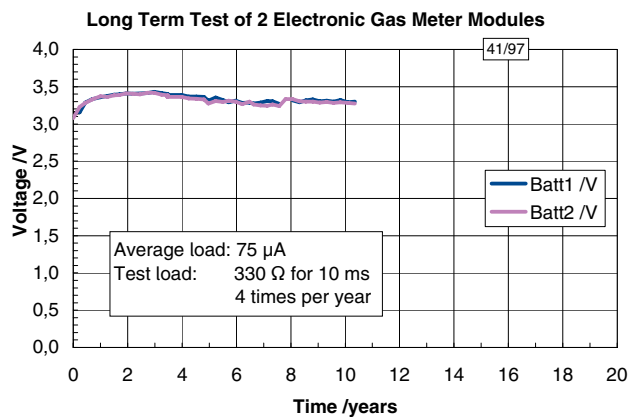

Figure 6
Long-term tests of meter circuit boards

Figure 6 shows the preliminary result of a similar test in which two circuit boards of an electronic meter are kept in continuous operation. The manufacturer had previously optimised the power consumption so that it was less than half the previous consumption. This test has now been underway for 10 years.

Batteries for prepayment meters with an RF module

One way of forwarding the measured values of a smart meter for analysis and presentation entails transmitting them a short distance to a data collector or communication module. Radio waves, which require around 10 milliamperes for creation, are one of the methods used for this purpose. Clever synchronisation of transmission intervals and use of components with low power consumption allow very long service lives to be achieved with relatively small batteries.

Table 6 shows a typical requirements profile for the battery used in this type of meter with a radio module. Suitable battery types are shown in Table 7.

Application	Electronic gas meter with RF function and shutoff valve
Voltage (U_{min})	3.0 volts
Operation	45 µA continuous current 7.5 mA for 10 ms every 2 s 25 mA for 50 s, once a week 25 mA for 4 s every 30 minutes
Average current	140 µA
Temperature	-20 °C ... +60 °C
Service life	11.5 years
Capacity requirement	14 Ah

Table 6
Typical battery requirements for electronic gas meters with radio module and shutoff valve.

System	Voltage per cell	No. of cells	Capacity	Service life (years)
BR-, CR-battery	2.7 ... 3.0 V	s2p2 C	10 Ah	5 – 10 years
LTC battery	3.2 ... 3.6 V	s1p1 D	19 Ah	Around 10 years
LTC battery with capacitor *)	3.2 ... 3.6 V	s1p1 D	19 Ah	10 – 20 years

*) for improved capacity utilisation

Table 7
Battery systems for meters with radio module and shutoff valve

Due to the voltage required, two cells connected in series were required when using a 3-Volt battery from the BR or CR system. Alternatively, a voltage converter (charge pump) could be used. To achieve the required capacity here, two size C cells would have to be connected in parallel. In contrast, these requirements can be met by just one LTC system cell. Ideally, a capacitor should also be connected in parallel. The aim of this is to improve the voltage and to achieve a longer service life. The capacitor should be sized in such a way that it can completely buffer the current pulses that occur.

Based on long-term measurements as shown in Figure 5, a database has been built up over the last 20 years that enables predictions based on a model calculation to be made concerning the battery service life and voltage for long-term use of lithium-thionyl chloride batteries. The model used takes account of, amongst other factors, the influences of average current, pulse current and temperature profile on self-discharge and the development of internal resistance of the battery. The result obtained for the requirements in Table 6 is a calculated discharge curve as shown in Figure 7.

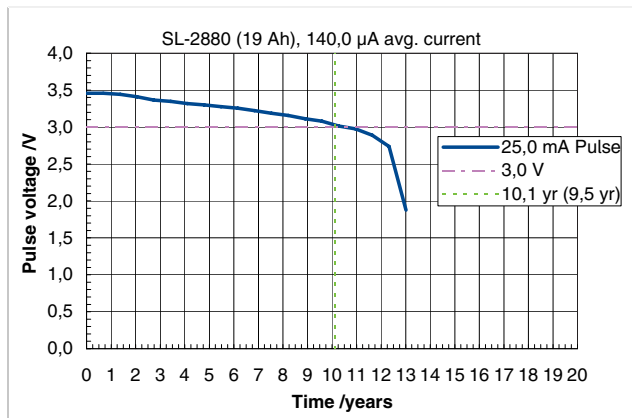

Figure 7
Model calculation with a D-cell, lithium-thionyl chloride system

In this case, it can be seen that the battery voltage in the application example will probably fall below the minimum value of 3.0 Volts after around 10 years, although the battery capacity would be sufficient for another 2 to 3 years. This is due to the rise in internal resistance. Figure 8 shows how the situation is improved if a capacitor of a suitable size is connected in parallel. If the capacitor is large enough to completely buffer the largest current pulse, the pre-calculated discharge curve is pushed so far upwards that the

expected service life now totals between 11.7 and 12 years.

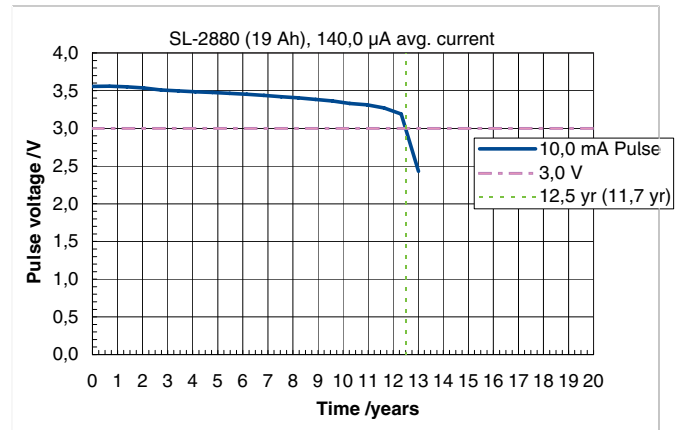

Figure 8
Model calculation as in Figure 7, but with a suitable capacitor connected in parallel

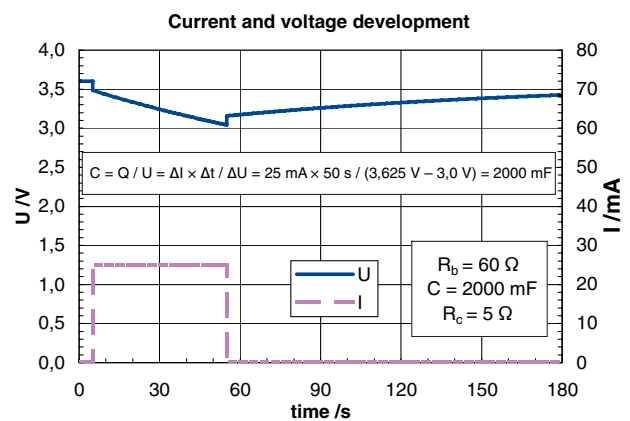

Figure 9
Calculation of capacitor size and current-voltage curve at capacitor

Figure 9 shows the calculation method and result for the required capacitor size. In addition, it also shows a model calculation for the current-voltage curve at the capacitor during the largest current pulse. Presumptions regarding the internal resistance, the capacitor (5 Ω) and the battery (60 Ω) are required.

The proposed capacitor has a relatively high capacity of 2000 mF. It puts an additional strain on the battery through the residual charge current (sometimes also referred to as the leakage current). To ensure the required battery service life, it is therefore appropriate to determine the residual charge current, especially if the manufacturer's data sheets do not contain any reliable statements concerning this value. Figure 10 shows the result of determining the

residual charge current of a 470 mF capacitor. It can be seen that the residual charge current, at a voltage of 3.67 Volts, fell to around 2 μA after 10 days and continued to fall. As a result, it could be ignored when calculating the battery life.

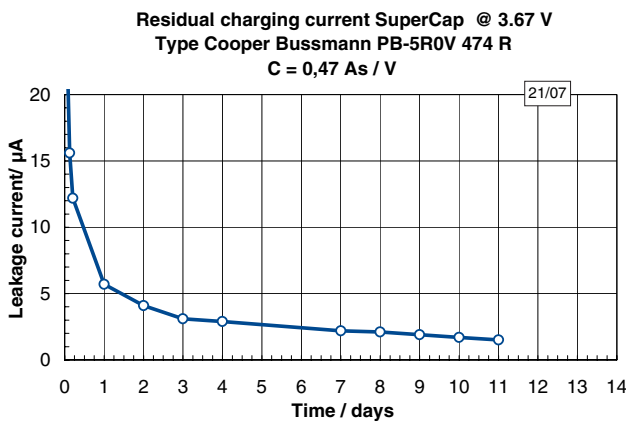

Figure 10
 Measuring the residual charge current of a suitable capacitor

Batteries for GSM radio modules

In the case of smart meters that are not operated in a closely meshed network, the measured data must be transmitted over large distances. Nowadays, the GSM network, which is also used to operate mobile phones, is highly suitable for this purpose. Current peaks in the ampere range occur here, as depicted in **Figure 11**.

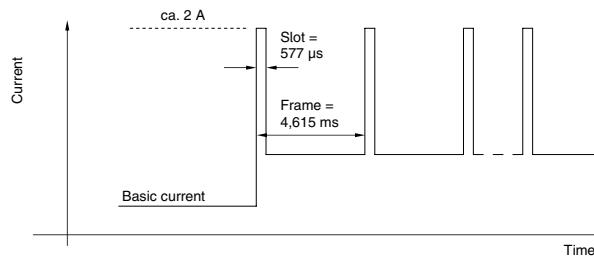

Figure 11
 Current profile of a GSM transmission module with an average transmission current of 300 mA

In the case of a GSM radio module, for instance, this may result in a current profile as shown in **Table 8**. In this example, the collected data is forwarded once a week via the GSM network. In addition, further data is transmitted once a month.

Application	GSM module for radio transmission with DC/DC converter
Voltage (U_{\min})	2.5 Volts (3.3 Volts for GSM module)
Operation	0 μA continuous current; 2500 mA for 577 μs at a duty cycle of 3 : 16 for 30 s, 78 times a year
Average current	35 μA
Temperature	-20 $^{\circ}\text{C}$... +40 $^{\circ}\text{C}$
Service life	11.5 years
Capacity requirement	3.5 Ah

Table 8
 Typical battery requirements for a GSM radio module with DC/DC converter

System	Voltage per cell	No. of cells	Nominal capacity	Service life (years)
LTC battery with electrolytic capacitor*)	2.5 – 3.6 V	s1p2 C	15.4 Ah 2500 μF	max. 5
LTC battery with HLC *)	2.5 – 3.6 V	s1p2 AA	4.8 Ah 155 mAh	10 – 20

*) for adjusting internal resistance

Table 9
 Batteries for a radio module with DC/DC converter

The tricky aspects of this application profile are to be found in the extremely dynamic nature of the current profile (5 powers of ten) and the high service life requirement. As shown in **Table 9**, there are two possible solutions that differ in terms of the size of the LTC batteries, and the capacity and technology of the capacitor used. In the first solution, 2 C cells are used in parallel, and current pulses are buffered using an electrolytic capacitor of 2500 μF . The average transmission current of 300 mA must be supplied by the battery during the transmission period of the GSM module. As laboratory tests and the model calculation show, it is necessary to increase the average continuous current of the battery from the required 35 μA to 200 μA in order to achieve the maximum battery

service life. Despite the high initial capacity of this variant, a battery service life of a mere five years can be achieved.

Figure 12 shows the result of the model calculation.

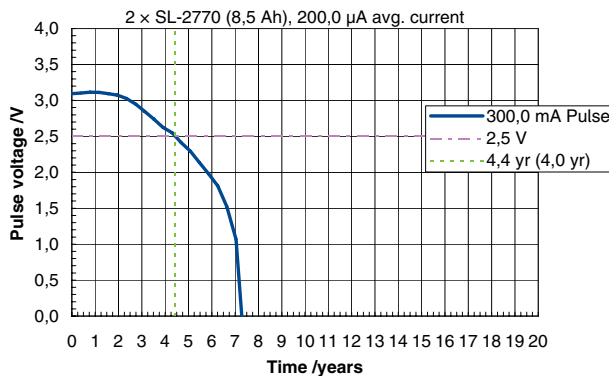

Figure 12
Service life calculation for GSM module.
2 C cells with electrolytic capacitor.

The second solution employs a hybrid layer capacitor (HLC). This technology has been available for the past eight years under the name *PulsesPlus* battery [6 - 9]. A size AA hybrid layer capacitor has a capacity of 155 mAh and, in the required temperature range, covers the entire power requirement of the radio module during the 30-second transmission duration. As a result, a considerably smaller primary battery can be used, in this case consisting of two size AA cells. This solution is very compact and comparatively cost-effective. The service life calculation (see Fig. 13) tells us that the requirement of 11.5 years can be reached in this way.

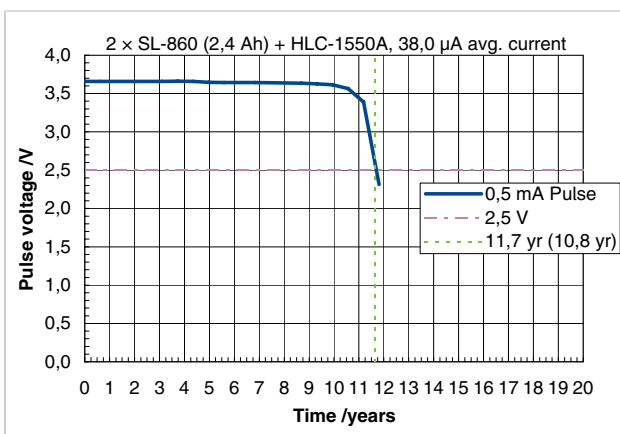

Figure 13
Service life calculation for GSM module.
2 AA cells with HLC

Figure 14 shows the current curve of the HLC during operation of a GSM module at various temperatures. The upper branch of the curve at each temperature corresponds to a basic current of 150 mA during transmission, while the lower branch of the curve corresponds to the surge current of 2 A.

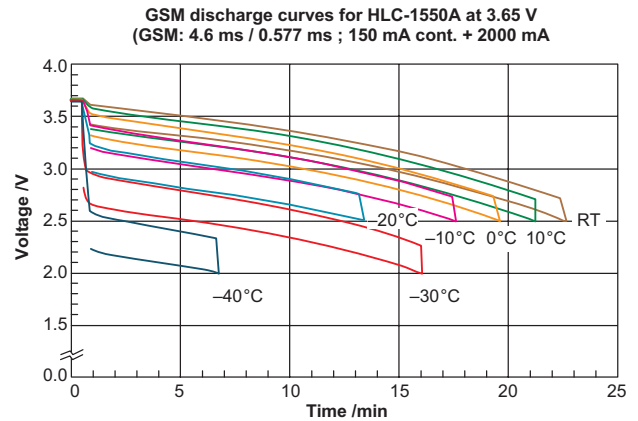

Figure 14
Voltage development of HLC-1550A during simulated GSM operation: continually 150 mA; 2 A peak for 577 μ s every 4.6 ms

The residual charge current of the HLC must also be taken into account. For this purpose, the residual charge current was determined over a timeframe of around 3 years. On average, the current is significantly lower than 3 μ A, as shown in Figure 15.

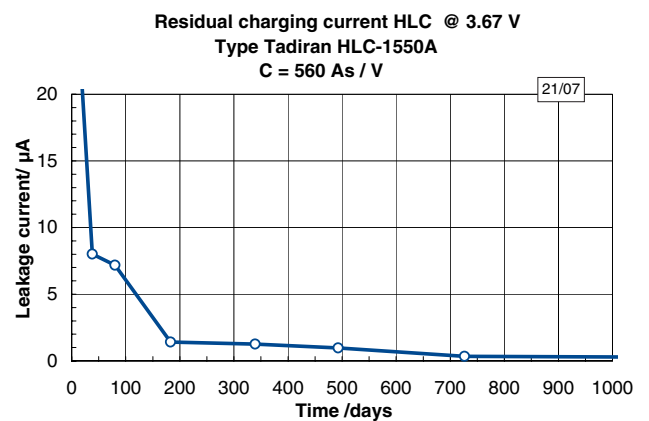

Figure 15
Residual charge current of HLC-1550A at 3.67 Volts

Tadiran battery recommendations

To sum up, Tadiran's battery recommendations for each of the four application examples are summarised in [Table 10](#). The details listed in this paper relate to concrete examples. Each application varies in its details, and should therefore be optimised individually. Tadiran offers comprehensive technical application support.

Example	Battery	Nominal capacity	Capacitor	Service life
Back-up and RTC	SL-350	1.2 Ah	–	10 – 20 years
Meter function	SL-2880	19 Ah	–	10 – 20 years
Prepayment meter with radio module	SL-2880	19 Ah	Electrolytic capacitor 2000 mF	10 – 20 years
GSM module	2 × SL-860	2 × 2.4 Ah	HLC-1550A	10 – 20 years

Table 10

Tadiran battery recommendations

References

- [1] S. Darby, *The Effectiveness of Feedback on Energy Consumption. A review for DEFRA of the literature on metering, billing and direct displays*, Environmental Change Institute, University of Oxford, April 2006
- [2] O. Franz, M. Wissner, F. Büllingen, C. Gries, C. Cremer, M. Klobasa, F. Sensfuß, S. Kimpeler, E. Baier, T. Lindner, H. Schäffler, W. Roth, M. Thoma, *Potenziale der Informations- und Kommunikations-Technologien zur Optimierung der Energieversorgung und des Energieverbrauchs (eEnergy)*, Study for the Federal Ministry of Economics and Technology (BMWi), wik Consult, FhG Verbund Energie, Bad Honnef, 21 December 2006
- [3] European directive 2006/32/EC on *Energy end-use efficiency and energy services* (L 114/64)
- [4] S. Jacobs, [Utility Meter Operating 20 Years on Original Lithium Battery](#), Metering International, 3, 2004,
- [5] *Smart Metering Projects Map*,
<http://maps.google.com/maps/ms?msa=0&msid=115519311058367534348.0000011362ac6d7d21187>
- [6] US Patent 5,998,052 (Dec. 7, 1999): Composite battery and methods of forming same
- [7] H. Yamin, E. Elster and M. Shlepakov, [Pulses Plus Battery System for High Energy High Power Applications](#), The 17th International Seminar on Primary and Secondary Batteries, Fort Lauderdale, Florida, 2000
- [8] H. Yamin, M. Babai, [Hybrid Primary Battery for Applications requiring High Current Pulses](#), Proceedings 39th Power Sources Conf., June 2000
- [9] C. Menachem, H. Yamin, [PULSES PLUS™ Battery System for Long Term and Wide Operating Temperature Range Applications](#), 19th Int. Seminar and Exhibit on Primary and Secondary Batteries, March 2002.



Tadiran Batteries GmbH
Industriestr. 22, 63654 BÜDINGEN, GERMANY
Phone: +49 (0)6042 /954-0
Fax: +49 (0)6042 /954-190
Email: info@tadiranbatteries.de
Internet: www.tadiranbatteries.de